

DIN 2181

HSS
code 146 XXX

Závitníky sadové Set of hand taps Satzgewindebohrer Метчики наборные

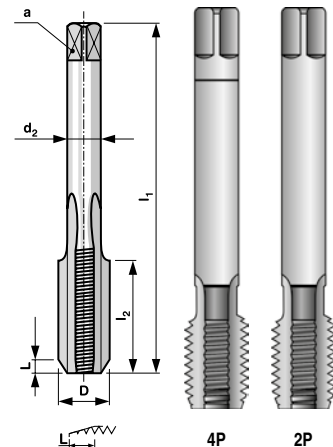
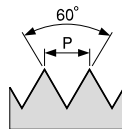
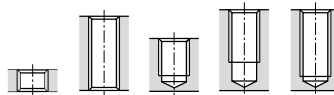

Lícování: 2B / Tolerance: 2B /
Toleranz: 2B / Подгонка: 2B

UNF

Unifikovaný jemný závit
Unified fine thread
Unifiziert-Feingewinde
Унифицированная мелкая резьба

D	z/1"	P	l ₁	l ₂	d ₂	a		*	code HSS
UNF 4	48	0,529	40	9	3,5	2,7	2,30	2	146 004
UNF 5	44	0,577	40	9	3,5	2,7	2,70	2	146 005
UNF 6	40	0,635	45	10	4	3	3,00	2	146 006
UNF 8	36	0,706	45	10	4,5	3,4	3,50	2	146 008
UNF 10	32	0,794	50	12	6	4,9	4,10	2	146 010
UNF 12	28	0,907	50	12	6	4,9	4,65	2	146 012
UNF 1/4	28	0,907	50	14	6	4,9	5,50	2	146 140
UNF 5/16	24	1,058	56	22	6	4,9	6,90	2	146 516
UNF 3/8	24	1,058	63	20	7	5,5	8,50	2	146 380
UNF 7/16	20	1,270	63	20	8	6,2	9,90	2	146 716
UNF 1/2	20	1,270	70	22	9	7	11,50	2	146 120
UNF 9/16	18	1,411	70	22	11	9	12,90	2	146 916
UNF 5/8	18	1,411	70	22	12	9	14,50	2	146 580
UNF 3/4	16	1,588	80	22	14	11	17,50	2	146 340
UNF 7/8	14	1,814	80	22	18	14,5	20,50	2	146 780
UNF 1	12	2,117	80	22	18	14,5	23,25	2	146 100
UNF 1 1/8	12	2,117	90	22	22	18	25,50	2	146 118
UNF 1 1/4	12	2,117	90	22	22	18	29,50	2	146 114
UNF 1 3/8	12	2,117	125	30	28	22	32,50	2	146 138
UNF 1 1/2	12	2,117	125	30	28	22	36,00	2	146 112

* kusy v sadě / pcs in set / Stck in Satz / штук в наборе



BUČOVICE
TOOLS a.s.

Materiál: HSS
Provedení: nebroušený závit

Material: HSS
Execution: non-ground thread

Werkstoff: HSS
Ausführung: nicht geschliffenes Gewinde

Материал: HSS
Изготовлено: нешлифованная резьба